

# Wall Mounted Touch Panel



Model No.: T1-1, T2-1, T3-1, T4-1

1-4 color/Glass panel/Touch color slide/DC input/4 channel constant voltage PWM output/Wireless remote control



T1-1



T2-1



T3-1



T4-1

## Features

CE RoHS LVD

- Touch panel single color, dual color, RGB or RGBW PWM constant voltage controller.
- Ultra sensitive high strength glass touch panel with touch color slide in the middle and backlighting.
- Compatibility with Skydance's 2.4G dimming remote control.
- Touch keys with chord tones and LED indicator.

## Technical Parameters

Input and Output				
Model	T1-1	T2-1	T3-1	T4-1
Input voltage	12-24VDC	12-24VDC	12-24VDC	12-24VDC
Input current	12.5A	12.5A	12.5A	12.5A
Output voltage	4 x (12-24)VDC	4 x (12-24)VDC	3 x (12-24)VDC	4 x (12-24)VDC
Output current	4CH,3A/CH	4CH,3A/CH	3CH,4A/CH	4CH,3A/CH
Output power	144-288W	144-288W	144-288W	144-288W
Output type	Constant voltage	Constant voltage	Constant voltage	Constant voltage
Light type	Single color	Dual color	RGB	RGBW

Safety and EMC	
EMC standard (EMC)	EN301 489,EN 62479
Safety standard(LVD)	EN60950
Radio Equipment(RED)	EN300 328
Certification	CE,EMC,LVD,RED





Environment	
Operation temperature	Ta: -30 °C ~ +55 °C
Case temperature (Max.)	Tc: +85 °C
IP rating	IP20

Warranty and Protection	
Warranty	5 years
Protection	Reverse Polarity

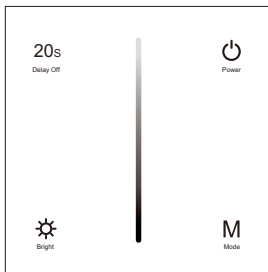
## Key function





### ● T1-1 Single color panel

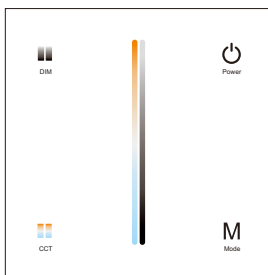

-  — Turn on/off light.
-  — Brightness slide.
-  — Brightness, 10 levels.
-  — Turn off light after 20s.
-  — Dynamic mode, 6 level speed.







### ● T2-1 Dual color panel

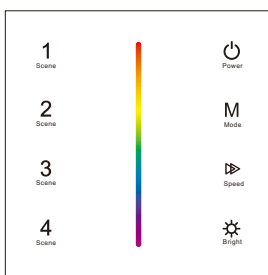

-  — Turn on/off light.
-  — Color / Brightness slide.
-  — Brightness, 10 levels.
-  — Color temperature, 11 levels.
-  — Dynamic mode, 6 level speed.







### ● T3-1 RGB panel

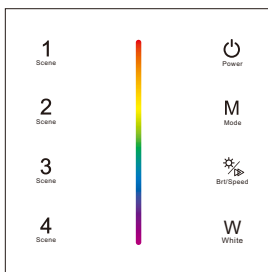

-  — Turn on/off light.
-  — Color slide.
-  — Brightness, 10 levels.
-  — Adjust dynamic mode speed, 10 levels.
-  — Short press play 10 built-in mode, long press 2s run mode-cycle.
-  — 4 Scenes, short press recall scene.  
Long press 2s to save the current color into 1/2/3/4.

### ● T4-1 RGBW panel



-  — Turn on/off light.
-  — Color slide.
-  — Adjust dynamic mode speed or static color brightness, 10 levels.
-  — Short press play 10 built-in mode, long press 2s run mode-cycle.
-  — Short press turn on/off W channel, long press adjust W channel brightness.
-  — 4 Scenes, short press recall scene.  
Long press 2s to save the current color into 1/2/3/4.

**Note:** After touch power key to turn off light, long press power key for 5 seconds will turn on or turn off tone.

## Wiring diagram

• T1-1 Single color panel

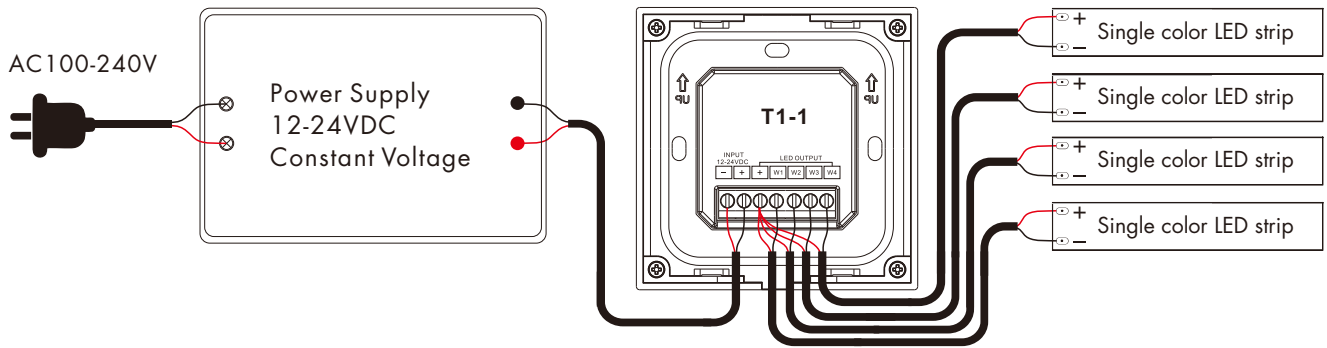

• T2-1 Dual color panel

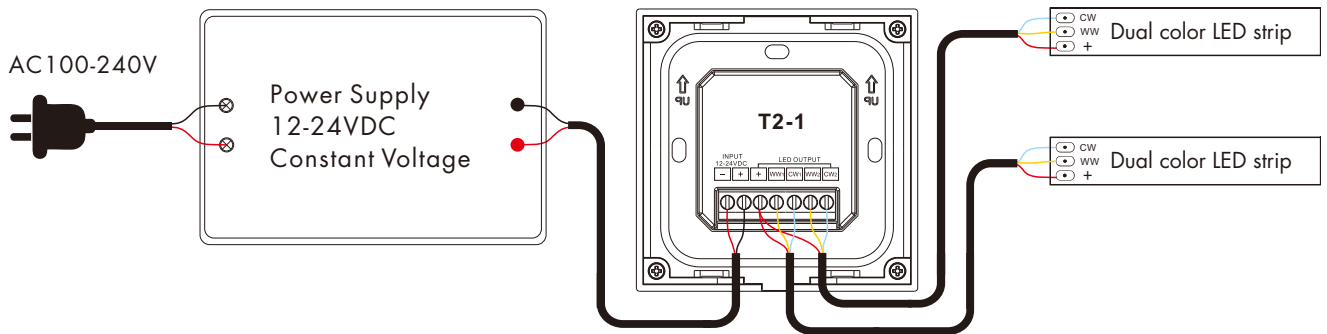

• T3-1 RGB panel

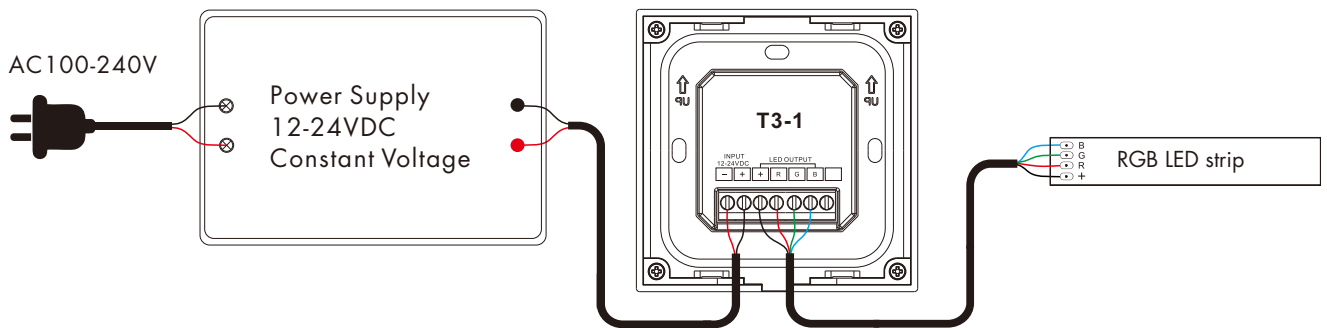

• T4-1 RGBW panel

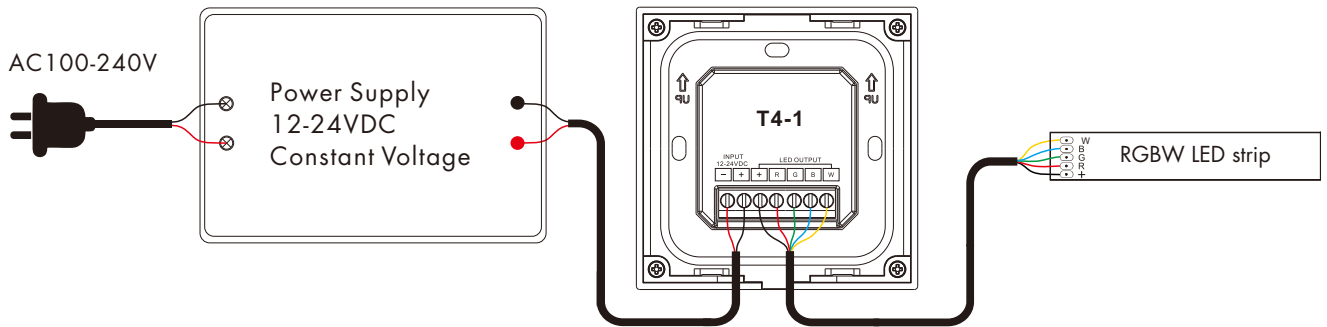

LED power supply voltage and power select :

- 12V lamp, Input 12V power supply, can load 0~144W,
- 24V lamp, Input 24V power supply, can load 0~288W, The power supply power must larger than load power 20%.

## Match Remote Control (two match ways)

The touch panel controller can also match with the RF remote (optional).  
End user can choose the suitable match/delete ways. Two options are offered for selection:

### Use On/Off key

Match:

Turn on light, turn off, immediately press the On/Off key of the panel for 5s, then press on/off key (single zone remote) or zone key (multiple zone remote) of the RF remote within 5s.

Delete:

Turn on light, turn off, immediately press the On/Off key of the panel for 10s, delete all matched RF remote.

### Use Power Restart

Match:

Switch off the power, then switch on power again, immediately short press on/off key (single zone remote) or zone key (multiple zone remote) 3 times on the remote. The light blinks 3 times means match is successful.

Delete:

Switch off the power, then switch on power again, immediately short press on/off key (single zone remote) or zone key (multiple zone remote) 5 times on the remote. The light blinks 5 times means all matched remotes were deleted.

## Mechanical Structures and Installations

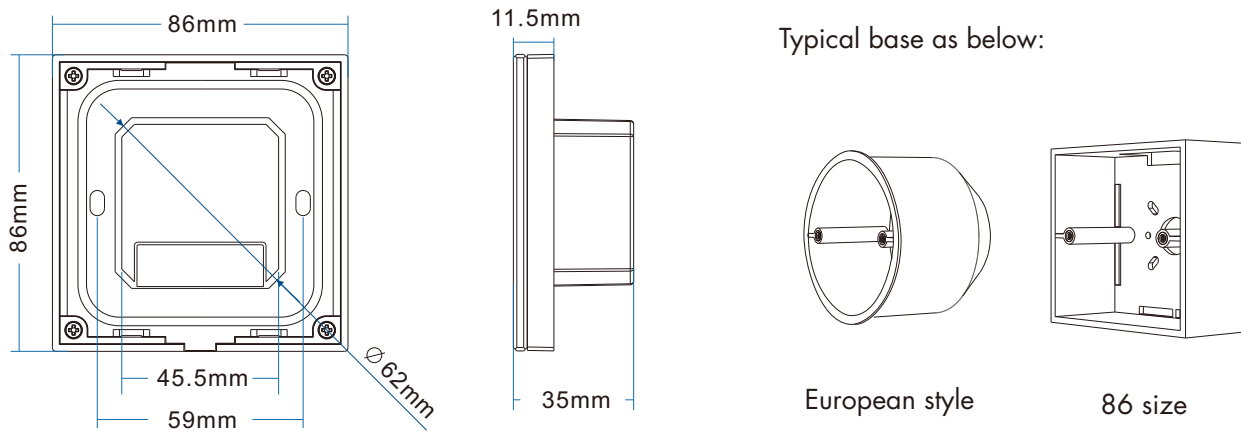

Installation diagram:

