

# SF18 Tunable White Silicone LED Linear Flex

SF18-24V-2835-120-DW

## Specification

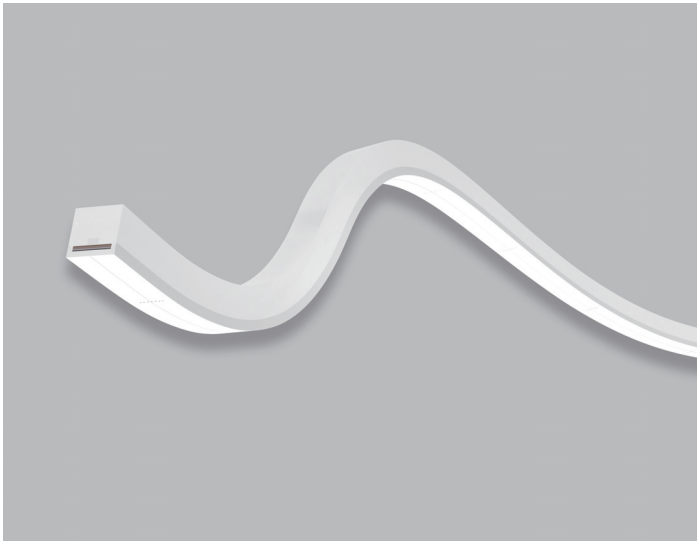

Dimension

Vertical Bending

Min. Bending Diameter

Beam Angle

Ansi C78.377

4 SDCM

One Bin

Dimmable

Submersible

Ambient Temp.

Class 3

LM-80

IK08

UV resistant

Anti-Yellowing

Flame Resistant

Saltwater Resistant

Solvents Resistant

Dirt Resistant

CE

RoHS

Warranty

## Technical Parameters

Electrical	
Input Voltage	24V DC
Power Consumption	15W/m
Physical	
LED Count	120 LEDs/m
Cutting Unit	12 LEDs
Cutting Unit Length	100mm
Minimum Bend Diameter	120mm
Output	
LED Light	Epistar SMD LED 2835
CRI	>80, >90
Max Run Length*	
Single Feed	10M
Double Feed	20M
Beam Angle	210°
Lumen Maintenance	70,000 Hours L70 @ 25°C 50,000 Hours L70 @ 50°C
Temperature Ranges	
Installation	0°C to 50°C
Operating	-40°C to 55°C
Dependability	
Warranty	5 Years Warranty
IP Rating	IP68 Wet location submersible <2m

Optional Color Combinations	Lumen Output
	2200K+5700K      290lm/m+400lm/m
	2700K+5700K      310lm/m+400lm/m
	3000K+5700K      310lm/m+400lm/m

## Illuminance Distribution

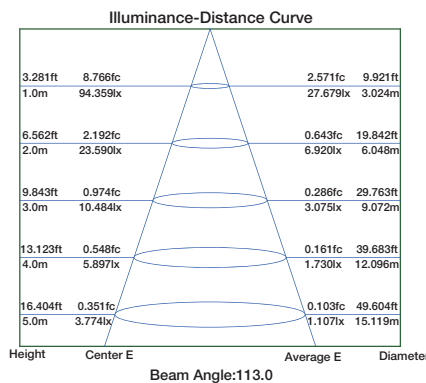
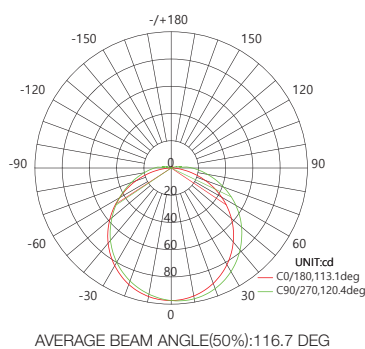

## White Color Charts

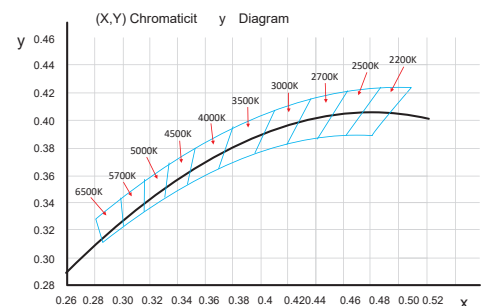

# SF18 Tunable White Silicone LED Linear Flex

## Connection

